

Advanced V-Control Ball Valves, 1/4" - 12"

Pneumatic, Electro-Pneumatic & Electric Controls

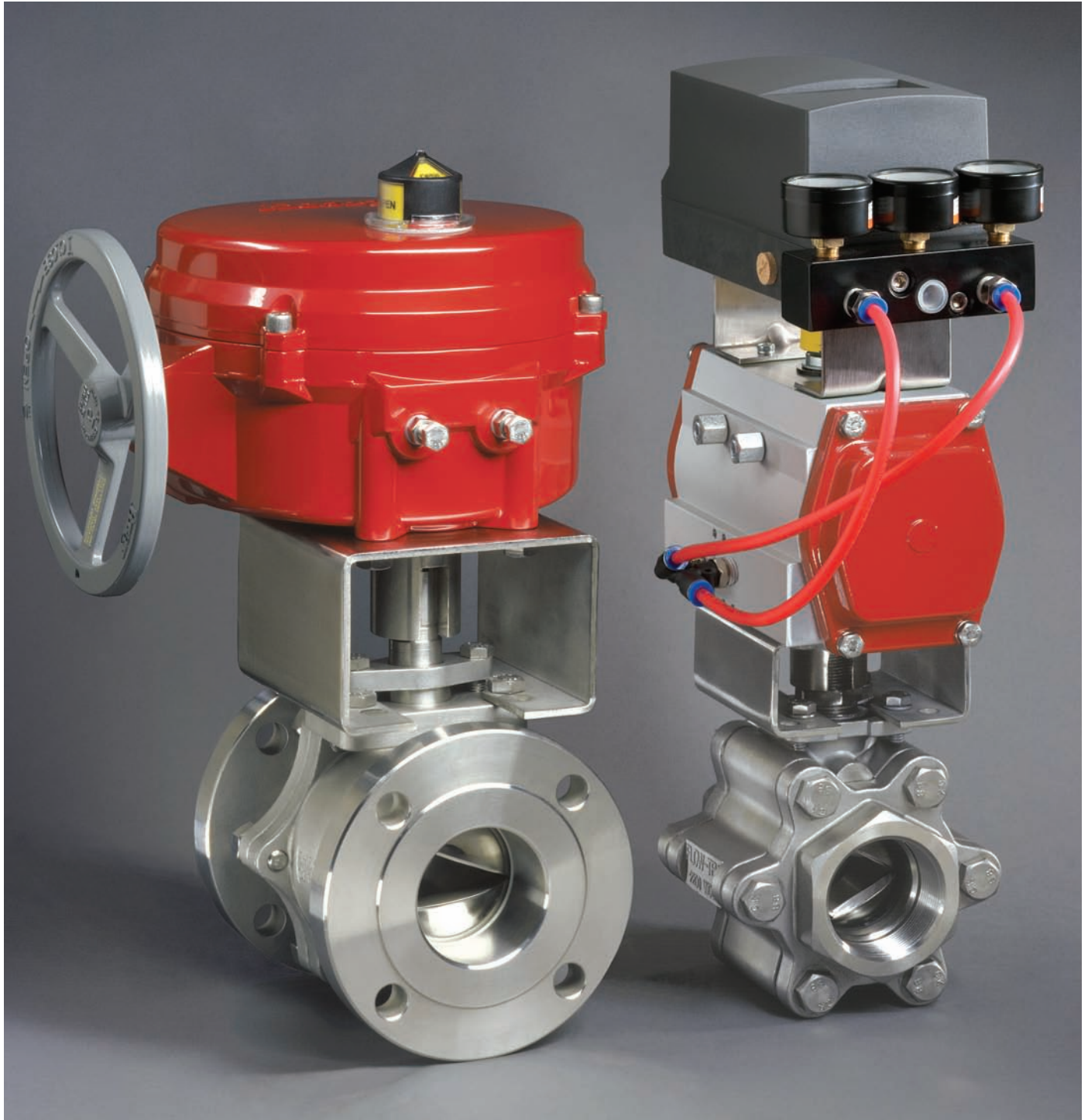

Threaded, Socket Weld, Butt Weld &
Flanged End Valves

Control Valves

V-Control Ball Valves with Pneumatic, Electro-Pneumatic and Electric Actuation

A BUBBLE TIGHT SHUT OFF VALVE AND PRECISION CONTROL VALVE COMBINED IN ONE

Standard round ported ball valves have been used, and continue to be used, for many control applications such as services involving moderate pressure drops. Now, with the development of Flow-Tek's characterized V-balls, a full range of control applications is available with superior flow control. These 1/4 turn control ball valves are more compact, lighter weight and much less expensive than comparably sized globe valves and segmented control valves offered by other companies. Flow-Tek control valves offer fast response times to control signals due to advanced digital control of actuation and the inherent strengths of ball valves. These valves exceed Class VI offering bubble tight shut off with zero leakage. Other features include superior rangeability and repeatability, high flow capacity, the ability to function with fluids containing solids and fibers, ease of maintenance and exceptional interface with PLCs and computer command signals. Flow-Tek high quality pneumatic and electric control actuators are very durable and efficient.

Increased Linear Response

Due to the in-line design inherent with characterized control ball valves, line media flows linearly through the piping system. The direct pattern provides increased media control and rapid response times to controller commands.

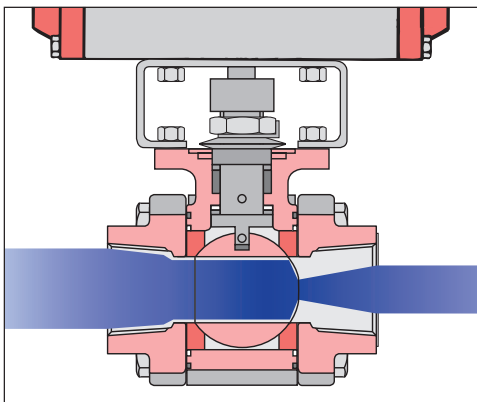

Media Flow entering valve from the left. Installing the V downstream is preferred.



15° V-Port

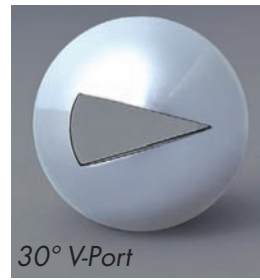

30° V-Port

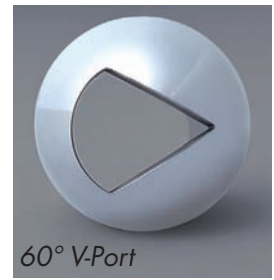

60° V-Port



90° V-Port



Custom Slotted Port

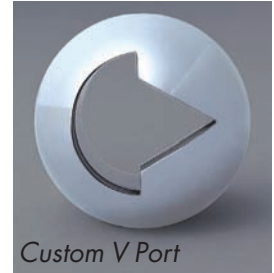

Custom V Port

Exceptional Characterized Control

Flow-Tek's characterized balls provide predictable and accurate control of downstream flow rates. These precision cut balls match the control performance of globe valves while offering the economy, features and reduced size and weight of ball valves. Flow-Tek offers a wide range of V-Port and Slotted Port characterized balls. The standard characterized balls and an example of a custom ball are shown above. The 90° and 60° balls, like standard round hole balls, offer an equal percentage inherent flow characteristic. A slotted ball and a V-Port ball with a small angle opening, such as a 15° ball, furnish a linear inherent flow characteristic. Medium angle V-Port valves such as a 30° ball furnish a modified equal percentage inherent flow characteristic. Custom ports are also available to meet special control requirements. Designed with flexibility in process conditions in mind, the C_v and control characteristics are easily changed by simply changing the ball.

High Rangeability

The characterized ball delivers controllable flow characteristics from the nearly closed to the fully open position of the valve. Though port type and valve size affects the rangeability, Flow-Tek characterized balls have a minimum rangeability of 200 to 1 and can exceed 800 to 1. Flow rates are highly repeatable within the normal 20% – 80% range of travel.

High Flow Capacity

Flow-Tek's control ball valves have been designed to offer maximum flow characteristics that are substantially higher than comparably sized globe valves. The inherent flow pattern of ball valves increases flow rates and in many applications valves smaller than pipeline size can be used. The self-cleaning action of the ball against the seat makes the ball valve acceptable for slurry and high fiber media services.

High Pressure Drops

Engineered to withstand high pressure drops while providing leak free operation, the V-Control Series delivers the precision control required by today's process industries. The ΔP limit for liquids is up to 500psi and steam is up to 300psi. Please consult the factory or your distributor for information on control valve sizing and pressure drop limitations.

Bidirectional Bubble Tight Shut Off

V-Control Series ball valves offer bidirectional bubble tight Class VI shut off in compliance with FCI 70-2 standards.



Ball Design

All Flow-Tek valves offer a precision machined, mirror finished, solid stainless steel ball. As with standard Flow-Tek round hole balls, the critical edges of the V-Port and slotted balls have blended curvatures to reduce seat wear and provide a high cycle life. Flow-Tek control valves have the cut in the ball instead of the seat — offering advantages of improved flexibility, durability and serviceability.

Flexibility: selection from the various standard balls and seats based on the application. Converting from a standard valve to a V-Port control valve is simply a matter of replacing the ball, all other valve parts remain the same. **Durability:** the pressure drop in a control valve is taken over the edges of the control element. Focusing the actual pressure drop at the edges of a V in the ball instead of in a soft seat material provides for a more durable product. **Serviceability:** when seat replacement is necessary, the center section of a Flow-Tek 3-piece valve can easily swing out for servicing. Competitors' valves, with the cut in the seat, require special end caps with a recess to accommodate the special seats. These end caps cannot swing out, requiring the valve to be completely removed from the line for servicing. Flow-Tek valves utilize standard end caps and seats for enhanced serviceability.

Characterized Control

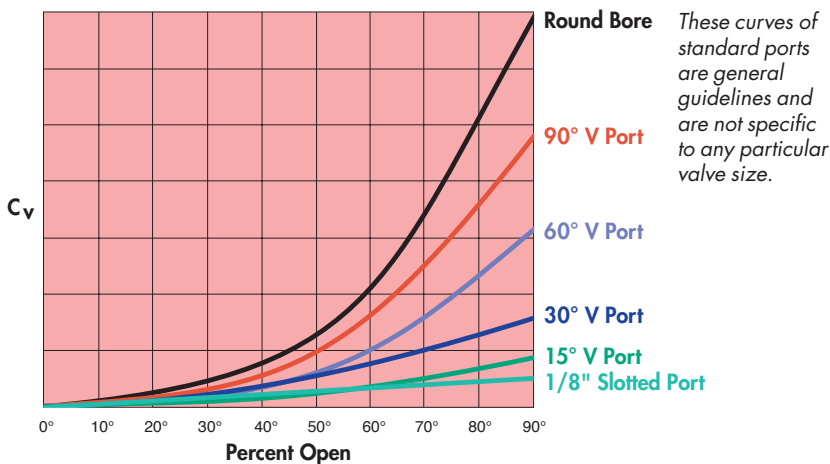

Hysteresis

Flow-Tek control valve packages are inherently designed to eliminate any measurable amount of hysteresis. This is a very important feature in throttling control. Flow-Tek valves were designed with a tight connection between ball and stem, and the large stem diameter increases the connection surface. Both ball and stem connections are precision machined to tight tolerances limiting any possible hysteresis. The Flow-Tek design does not require hand matching of balls and stems to insure a tight connection. Standard valves can be converted to V-Port control valves in the field. Heavy duty brackets and couplers connect valves to actuators. Pneumatic actuator pistons have standard guide bearings to minimize side movement within the actuator body. All connections are manufactured to tight tolerances throughout the control valve package.

Stem Seals & Seats

Leak-free protection is achieved by Flow-Tek's stem packing design, live-loaded self-adjusting stem seals and superior seat construction. In combination with the long lasting service capabilities of Flow-Tek actuators, V-Control Series ball valves have a much higher cycle life than most control valves. With a low coefficient of friction and high resistance to erosion and corrosion, Flow-Tek valves are built to last.

Control Valves

Seat Selection

A wide range of seat materials are offered to meet most applications. Seats include RPTFE, TFM 1600, Stainless Steel/PTFE (50/50), UHMWPE, PEEK and Tek-Fil® seats offering high temperature and high pressure capabilities. Metal and other seats are available, please consult the factory.

Applications

Temperature Control With shut off meeting Class VI requirements, these valves are ideal for steam/temperature control.

Flow Control The high flow capacity and predictable rangeability and repeatability of the V-Control Series valves make this the ideal choice for flow control services.

Steam Control The V-Control Series provides tight shutoff and utilizes Flow-Tek's live loaded Smart Stem design to eliminate typical problems of downstream leakage and stem leakage associated with globe style steam control valves.

Cavitation In applications where the possibility of cavitation exists, the valve should be installed with the V downstream to prevent damage to the valve body.

Level Control & PH Service A combination of Flow-Tek control actuation and standard round hole balls are the ideal package for these applications.

Media Containment Units Extended stem sealing units are designed to prevent costly downtime and provide double stem sealing. A button-head check valve for injection of a sealing agent can be added.



Pneumatic Controls

Digitally Controlled Ball Valves For Precision Pneumatic Control Of Flow

The Flow-Tek Automator Pneumatic Control Actuator is equipped with advanced electro-pneumatic or pneumatic positioners for precise valve positioning. In combination with Flow-Tek's V-control balls, the Automator offers superior flow control. Series 6A electro-pneumatic positioners feature advanced communication and enhanced diagnostics. The Automator Series pneumatic actuators are rack and pinion, opposed-piston actuators designed with innovative, high performance features in a compact, rugged and reliable modular product line.

Automator Series Pneumatic Control Actuators offer many design features including:

- Double Acting and Spring Return units.
- Manual override.
- Highly visible valve status display.
- Externally adjustable bidirectional travel stops.
- Valve mounting to ISO 5211 standards without external piping. NAMUR standard mounting of accessories.
- Spring return units with spring cartridge system offers safety, simplicity and reduced space requirements. Spring return units have the same dimension as the double acting.
- Supply air pressure to 140 psi (10bar).
- Size 48 actuators have 1/8" NPT pneumatic air connections. Larger sizes have 1/4" NPT connections.
- Permanently lubricated piston guides, rings and output shaft bearings.
- Interchangeable modular positioner units and accessories.
- Low hysteresis through tight tolerance ball, stem and shaft connections.

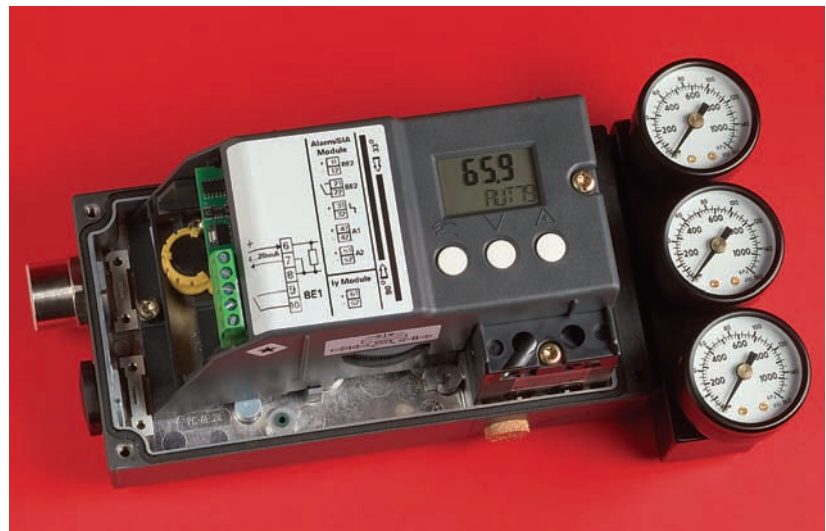

Intelligent Electro-Pneumatic Positioners

Flow-Tek's Series 6A Electro-Pneumatic Positioners are microprocessor controlled, delivering all the benefits of digital electronics to a pneumatic actuator. The microprocessor constantly compares the command signal to the actual valve position and makes precise, on-line adjustments until the two measurements match within the user-selectable deadband. These positioners can accept an analog 4-20 mA, HART, Foundation Fieldbus or PROFIBUS PA input command signal. Utilizing proven technology, Series 6A electro-pneumatic positioners feature rugged reliability, high quality components and outstanding performance.

Minimal Air Consumption Series 6A positioners offer the lowest air consumption on the market today, <0.00035 scfm at 80 psi. Air supply within the unit is controlled by Piezo valve technology, resulting in reduced air consumption during operation and zero bleed during steady state. The energy savings alone can pay for the cost of the unit within a year. In addition, the power conservation and decreased noise are beneficial to the environment. Maximum supply air pressure is 102 psi (7 bar).

Diagnostics Flow-Tek's intelligent positioners feature corrective and preventative maintenance self-diagnostic checks. Corrective maintenance diagnostics aid in finding the cause of a problem. Preventative maintenance diagnostics checks reduce operating costs by identifying potential problems as they occur. Diagnostic results are indicated both via a PC connection and the local LCD. All diagnostics run constantly. The data may be continually monitored and recorded via a PC.

Enclosures Flow-Tek waterproof positioners meet NEMA 4, 4x and IP66 specifications. The waterproof enclosure is constructed of a durable, light-weight polymer, providing excellent chemical and corrosion resistance.

Waterproof/Explosion Proof enclosures meet NEMA 4, 4x, 7 & 9 specifications. These enclosures are constructed of die cast aluminum with an epoxy coating for chemical and corrosion protection.

A waterproof stainless steel enclosure is available upon request.

Position Indicator In addition to an LCD display, valve position is clearly shown over a distance by a yellow indicator. Made of ABS plastic material, the pointer is located between Flow-Tek pneumatic actuators and the Series 6A housing.

Accessories An externally mounted Gauge Manifold is offered with up to 3 gauges to measure air supply and the actuator input and output pressures. Volume Boosters increase air volume output and decrease response time. Filters & Regulators condition the incoming air supply.



LCD Display & Keypad

Flow-Tek's Series 6A LCD Display provides visual confirmation of valve position, operating status and keypad entries. With the housing cover on, the Display clearly shows actual valve position in precise one degree increments. The positioner operating mode (automatic or manual) and alarm messages are also shown.

With the housing cover removed, the keypad push buttons are accessible to perform a variety of functions, including automatic calibration, confirmation of the setpoint and progress to the setpoint, potentiometer alignment, diagnostic checks, and error messages. Additional parameters are available, please consult the factory for more information. The LCD Display shows the information entered in the keypad.

Auto Calibration

Series 6A calibration push buttons are accessible under the housing cover. Calibration is easily performed by entering only three parameters into keypad push buttons. The LCD Display provides visual confirmation of parameter values. The calibration process automatically determines the position of the travel limit stops, then measures and records the parameters for both the open and close positions. The settings are stored in nonvolatile memory to prevent loss in the event of power failure. After performing the calibration procedure, which normally takes less than 5 minutes, the Series 6A is ready for operation.

Adaptive Control

Unique to the industry, the Series 6A delivers on-line adaptive control. During the calibration process, the positioner characterizes the profile of the valve load and automatically adjusts the output air volume to an appropriate value. During operation, the unit continually optimizes control behaviors and travel times in response to changes in line media pressure. The benefits are product efficiency, reduced maintenance, increased service life and lower operational costs. This unique on-line adaptation continually optimizes field performance and sets the Series 6A apart from any competitor.

Bus Intelligence

Flow-Tek offers Series 6A Intelligent Electro-Pneumatic Positioners with serial bus network flexibility. HART, Foundation Fieldbus and Profibus PA protocols are available. Flow-Tek's bus intelligent positioners offer all Series 6A features plus increased network communication and remote access to positioner parameters and diagnostics.

Bus networks greatly reduce plant engineering and installation costs and allow for future flexibility. Adding units is easily done by just connecting the appropriate bus cable. Series 6A bus intelligent positioners can be configured from Windows based HMI and a bus modem. These units may provide a variety of detailed information on the history and operating state of the actuators, such as number of cycles, ambient temperature limits, and any air leakage. They also log every alarm message.



Pneumatic Controls

Optional Boards

Retransmission Module indicates valve position to the control room.

Programmable Electronic Switches can be set to activate at various travel position. 2 semiconductor switch outputs and 1 alarm output, plus 1 digital input are included.

Limit Switches provide cam activated indication of travel limits – mechanical switches or intrinsically safe inductive proximity switches are offered.

All optional boards can be easily installed in the field.



Explosion Proof Positioners

Designed for hazardous and severe applications, Flow-Tek's Series 6A explosion proof positioners offer all the features of the waterproof units in a flameproof enclosure. Non-intrinsically safe boards may be placed inside. These rugged, heavy duty units meet EExd IIC T4/T5/T6 specifications. The Automatic Calibration keypad in the explosion proof units are externally mounted and easily accessible. The units can be controlled locally, even during operation, without removing the housing cover. The LCD display is viewed from behind an explosion proof window.

Pneumatic Positioners

Flow-Tek's Pneumatic Positioner automatically positions the output shaft to precise valve angles between 0° and 90°. The standard input signal is 3-15 psi. It can function as double acting or spring return and is adaptable for applications where reversible or split range is required.

Electric Controls

Digitally Controlled Ball Valves For Precision Electric Control Of Flow

The Flow-Tek Series 70 Electric Actuator is equipped with a digital Servo for precise valve positioning. In combination with Flow-Tek's V-control balls, the Series 70 offers superior flow control. Two digital versions are offered – an analog input unit and *BusSmart* units with serial bus protocols. The Servo consists of a circuit board and a feedback potentiometer assembly, which both fit entirely within the standard Series 70 actuator housing. The circuit board has a screw-type terminal for ease of customer field wiring. Other terminals for internal connections to the actuator components are wired at the factory. The feedback potentiometer is driven by a gearset connected to the output drive.

Flow-Tek's unique digitally controlled Electric Actuators have many design advantages over present industry standards including:

- Simple and unique manual override handwheel system
- Lowest profile and lightest weight actuator on the market
- Simple finger or screw driver adjustment of travel limit cams without interference from other components
- Highly visible valve status display
- Externally adjustable travel stops
- Optional Torque Limiting Switching System: Switches independently respond to predetermined loads in both the open and closed directions by sensing the movement of the worm gear shaft, then interrupt the electrical power to the motor. The switches can operate at any point of actuator travel.
- Optional anticondensation Heater
- Optional Local Control Box.

The die-cast aluminum cover and base are waterproof (NEMA 4,4X, IP 65) and high-quality polyester powder coated for exceptional corrosion, wear, impact and ultra-violet resistance.

An Explosion Proof unit with the same features as the waterproof unit is available in some sizes. This unit is designed to meet NEMA 4,4X,7,9.

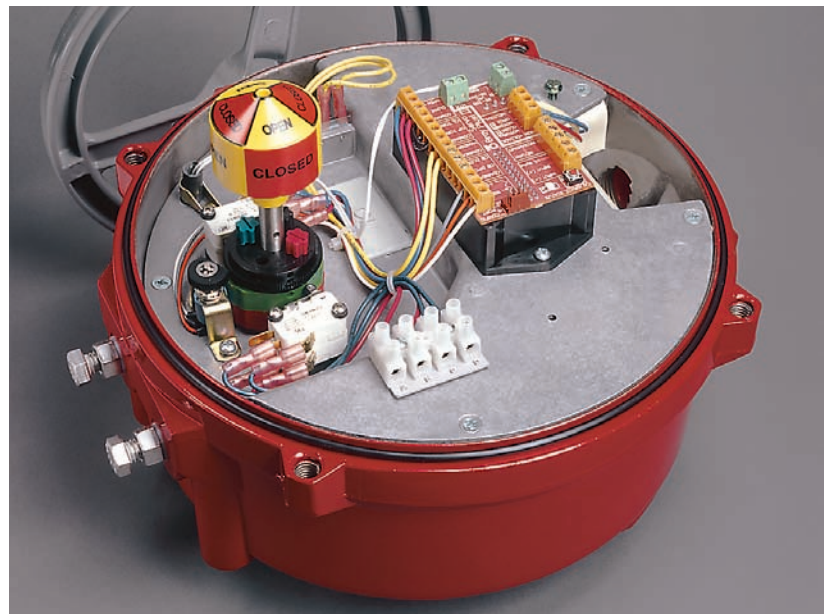

Digitally Controlled Analog Electric Actuators

The Series 70 with Servo Plus II delivers all the benefits of digital electronics to an actuator that responds to analog signals. The unit positions the valve in response to an analog command signal and produces an analog output signal of actual valve position. A microprocessor constantly compares the command signal to the actual valve position and makes precise adjustments until the two measurements match within the user-selectable deadband.

Features

The Servo Plus II features self-diagnostic checks which run constantly. The self-diagnostic results are visually indicated by locally flashing LEDs or graphically on a PC through the Configuration Tool Software. Self-diagnostics reduce operating and maintenance costs by identifying problems as they occur. Self-diagnostics include status indication operation, control signal & feedback pot calibrations, reverse acting & split range warnings, calibration in progress, handwheel engagement, command signal failure, feedback pot failure, travel limit switch failure, open & closed torque limit reached, feedback pot wired in reverse, and calibration invalid.

The Servo Plus II can be used with either 110 or 220 VAC actuators without changing jumpers or switches. User adjustable parameters include tailored bidirectional motor speed control & range, deadband, fail position upon loss of command signal, and run through protection by instant reverse delay.

Autocalibration

The Servo Plus II electric actuator offers **one touch** calibration. Complicated potentiometer and switch settings are eliminated. A signal generator is not required since the microprocessor already understands a 4-20 mA command signal. With the touch of a button, the auto calibration routine moves the actuator to the open and closed positions until the travel limit switches are reached. The settings are then stored in non-volatile memory to survive power outages. If limit switches are adjusted later, the autocalibration can be simply repeated.

Configuration Tool (OPTIONAL)

An optional Servo Plus Access Cable connects the Servo Plus II module to a personal computer running the Configuration Tool software. The program visually presents in highlighted text actuator operational conditions and parameter settings, and allows the user to easily make configuration adjustments.



Electric Controls

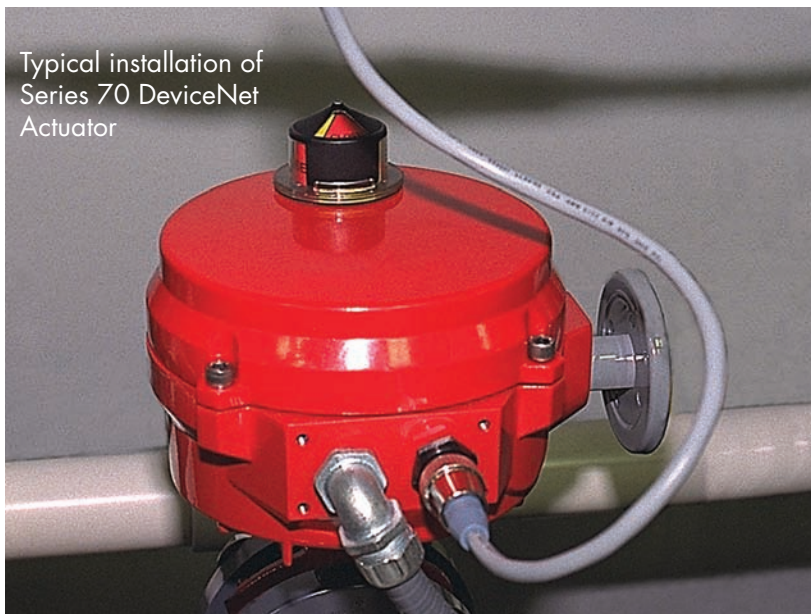

Typical installation of Series 70 DeviceNet Actuator

BusSmart Electric Actuators

The Flow-Tek *BusSmart* DeviceNet Servo is microprocessor controlled and serial bus connected using firmware specifically designed to complement the capabilities of the Automator Series 70 Electric Actuator. The microprocessor continually responds to commands from the process controller or PLC, supplying information such as valve position, limit switch positions, and other parameters through a single network address, or MAC ID. The *BusSmart* Servo is fully ODVA (Open DeviceNet Vendor Association) compliant and can be configured, monitored and controlled over a single DeviceNet cable.

Features

The *BusSmart* Servo has the following features: **LED Indicators** – Power, Network/Module Status, Motor Running Open, Motor Running Closed and Calibration Status; **Network Adjustable Parameters** – Command Signal, Speed Control, Instant Reverse Delay, Service Notes, Reset, Restore Default Settings and Remote Autocalibration; **Network Viewable Parameters** – Actual Position, Motor Temperature, Motor Current and Serial Number.

Operation

The *BusSmart* Servo is easy to install and configure, similar to connecting a printer to a personal computer. Network communication wiring is accomplished through a single DeviceNet standard five-pin connector cable, and power to drive the actuator motor is brought to a terminal strip inside the actuator. Installation costs are greatly reduced. Configuration of features is made with Electronic Data Sheets (EDS) files and commercially available software. Calibration is a simple automatic process accomplished without complicated potentiometer and switch settings, and may be made with or without connection to the network. All configuration settings are stored in non-volatile memory and will survive power outages.

Electronic Data Sheet (EDS)

Flow-Tek's EDS simplifies installation, commissioning and monitoring. Configuration of features is made with EDS files and commercially available software that uses the EDS to present a clear graphic user interface for remote viewing and control. Similar to a spreadsheet, the EDS describes the various supported features of the *BusSmart* Servo.

DeviceNet

An economical internationally recognized fieldbus network, DeviceNet is used to connect devices such as sensors and actuators while providing access to the intelligence present in those devices. Polled messages exchange data many times per second. Each scanner card in a PLC allows up to 64 devices to communicate with each other over a single cable. PLCs may use multiple scanners to connect as many devices as required.

DeviceNet Advantages

The DeviceNet fieldbus network greatly increases plant operation flexibility, efficiency and maintenance, and reduces installation and engineering costs.

Flexibility A wide variety of devices, such as control valves, sensors, motor controllers, pump controls, scanners, etc., can be installed along the DeviceNet trunk line by means of tap connectors. Devices can be removed or replaced while the network is operational. Additional devices can be added by simply connecting them to the existing bus line.

Efficiency The two way communication capacity of the network allows devices to provide information back to the controller, as well as respond to commands. Precise actuator position control and modification of parameters, such as valve travel limits and actuator speeds, can be easily performed. The entire plant can be controlled and monitored from a remote location.

Maintenance Diagnostic information such as motor temperature and current can be easily accessed from both local and remote locations over the network. Therefore, maintenance schedules can be planned and modified based on live information.

Installation Traditionally, plant controllers require one to two wires per function, per device. These wires must be physically run and identified throughout the plant. The labor, material, engineering and record keeping for any control system is time consuming and expensive. The DeviceNet fieldbus network eliminates these costs, delivering tremendous overall savings and enhanced performance.

Ball Valves



Valve Type	Porting	Body Materials	Sizes (ins)	Pressure Rating ASME	Pressure Drop Limit†	Seat Materials	End Connections
3-Piece: Triad	Full Port & Standard Port	Stainless Steel & Carbon Steel	Full Port: 1/4 to 4 Std. Port: 3/4 to 2 1/2	Class 600	Liquids: 500 psi Steam: 300 psi	RPTFE, TFM, Tek-Fil® PEEK, Metal	Threaded (NPT) Socket Weld Butt Weld
3-Piece: 7000/8000	Full Port	Stainless Steel & Carbon Steel	1/4 to 12	1/4 to 6": Class 150 1/4 to 4": Class 300	Liquids: 80 psi Steam: 50 psi Liquids: 225 psi Steam: 150 psi	RPTFE, Tek-Fil®	Threaded (NPT) Socket Weld Butt Weld Quick Clamp Raised Face Flanges
Flanged: F15/F30 & RF15/RF30	Full Port & Standard Port	Stainless Steel & Carbon Steel	Full Port: 1/2 to 12 Std. Port: 1 - 12	Class 150 Class 300	Liquids: 80/225* Steam: 50/150 psi*	RPTFE, TFM, Tek-Fil® PEEK, Metal	Raised Face Flanges

†Consult Flow-Tek factory or your distributor for information on control valve sizing and pressure drop limitations.

* Limited to ASME pressure rating for Class 150 valves.

3-Piece Valves



Triad Series Valves

Triad Series ball valves are designed for heavy duty, high pressure applications and feature a redundant body seal.

7000/8000 Series Valves

7000/8000 Series ball valves are available in a wide range of end connections and seat materials.

Flanged Valves

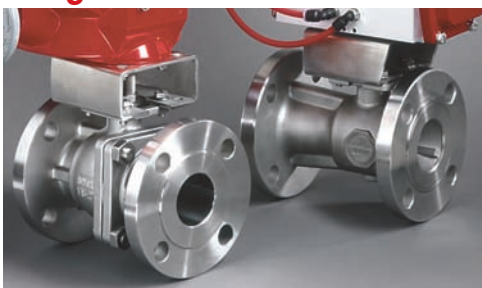

F15/F30/RF15/RF30 Series Valves

Flow-Tek Flanged ball valves are ideal for industrial applications. Larger F15/F30 valves feature ball support.

For more detailed information please refer to valve brochures in the Product Manual.

Stem Assemblies

Flow-Tek features heavy duty, high quality stem designs with double "D" connections to ball and operator mounting. This connection simplifies mounting and indicates direction of flow. Stems are mated with the ball to ensure positive contact. All Flow-Tek stems are internal entry and blowout proof for maximum safety.

Smart Stem Valve Sizes 1/4" through 2-1/2"

Flow-Tek's control valves feature strong, large diameter stems with live-loaded, self-adjusting sealing utilizing belleville washers that automatically adjust to compensate for changes in temperature and wear. Manual adjustments that can cause damage to the seal are not required. The assembly is secured by a saddle-type lock washer that prevents stem nuts from unthreading in high cycle automation applications.

Stem Design: Valve Sizes 3" through 12"

The stem is guided by the valve body and the gland, ensuring smooth operation even in high torque service. The independent packing gland can be easily adjusted without removing mounting hardware or actuator. The user-friendly packing gland and gland sleeve are V-slotted to more equally distribute the load in the event one side is over tightened. All stems are polished to reduce torque. For severe applications, optional belleville washers can be added for a self-adjusting live load, providing a continuous compression seal.

Fire Safe Valves

Flow-Tek 3-Piece and Flanged valves are available as non-fire safe and Fire Safe to API 607 4th Edition standards. Flow-Tek's standard fire safe design features metal to metal ball to body contact during and after a fire, graphite stem packing, thrust bearings of stainless steel/PTFE, and graphite body seals. **Anti-Static Protection:** All Flow-Tek stems feature anti-static grounding devices as standard. These devices ensure electrical continuity between valve ball, stem and body, thus eliminating the possibility of static electric charges creating sparks within the valve.

Actuator Mounting

All V-Control Series ball valves feature Flow-Tek's Secure Mount actuator top plate mounting. The mounting is designed in accordance with ISO 5211 standards.

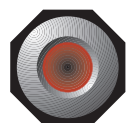

Flow-Tek®

A Subsidiary of BRAY INTERNATIONAL, Inc.
8323 N. Eldridge Pkwy #100 Houston, Texas 77041
832.912.2300 Fax: 832.912.2301
www.flow-tek.com

All statements, technical information, and recommendations in this bulletin are for general use only. Consult Flow-Tek representatives or factory for the specific requirements and material selection for your intended application. The right to change or modify product design or product without prior notice is reserved.

Flow-Tek® is a registered trademark of Flow-Tek, Inc.
© 2008 Flow-Tek, Inc.
F-2600_EN_VC_2008-11